

## Swing Check Valve – Series 426 Installation, Operation, and Maintenance Instructions

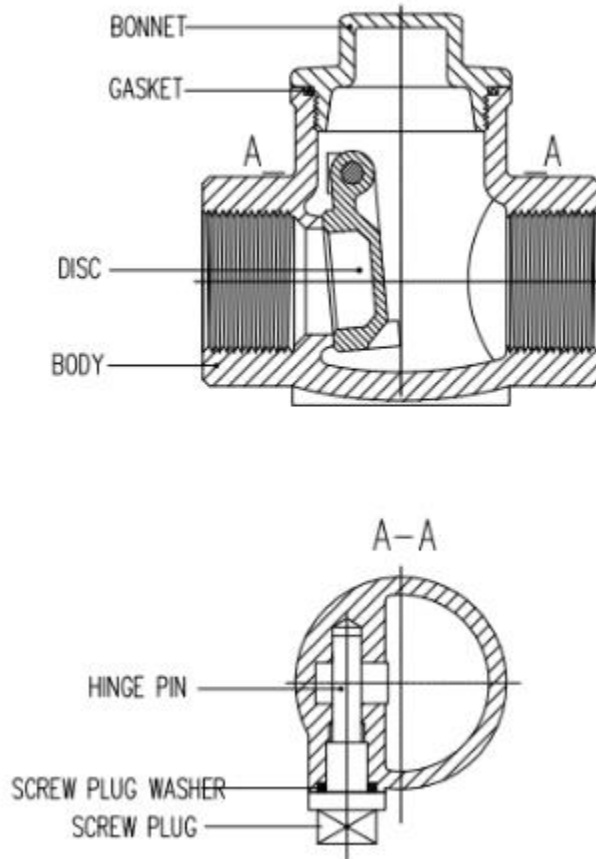

### **INSTALLATION:**

These valves should be installed in a horizontal pipeline with the body vertical, using good piping practice. They may also be installed in a vertical pipeline, as long as the flow arrow on the body points up. Use a suitable joint compound or TFE tape on pipe threads for ease of fit-up.

## **OPERATION:**

Swing check valve operation is automatic; no operator action is required. They are designed to permit flow in only one direction and stop flow in the reverse direction. A flow arrow on the side of the body indicates the direction of fluid flow.

## **MAINTENANCE:**

**----WARNING----**  
**Do not attempt to perform  
maintenance on valves in  
pressurized lines.**

In normal service, no preventive maintenance is required for these valves. They do not require lubrication or adjustment. Should the valve disc or seat become worn over time such that performance is not acceptable, the valve should be replaced.