

Chicago Valves & controls



SERIES 36

THREE PIECE SANITARY

BALL VALVE

Series 36

1/2" - 4"

- TUBE FULL PORT DESIGN
- 316 STAINLESS STEEL BODY & ENDS
- LIVE LOADED STEM
- BLOW OUT PROOF STEM
- DIRECT MOUNTED ACTUATOR
- ELEVATED MOUNTING PAD ALLOWING TO ADJUST GLAND PACKING FLANGE WHILE THE VALVE IS IN SERVICE, WITHOUT REMOVING THE ACTUATOR
- TRI CLAMP ENDS CONNECTIONS
- INTERIOR FINISH 14-18 RA/240 GRIT
- ANTI-STATIC DESIGN
- LOCKABLE HANDLE
- SILICONE FREE OPTIONAL

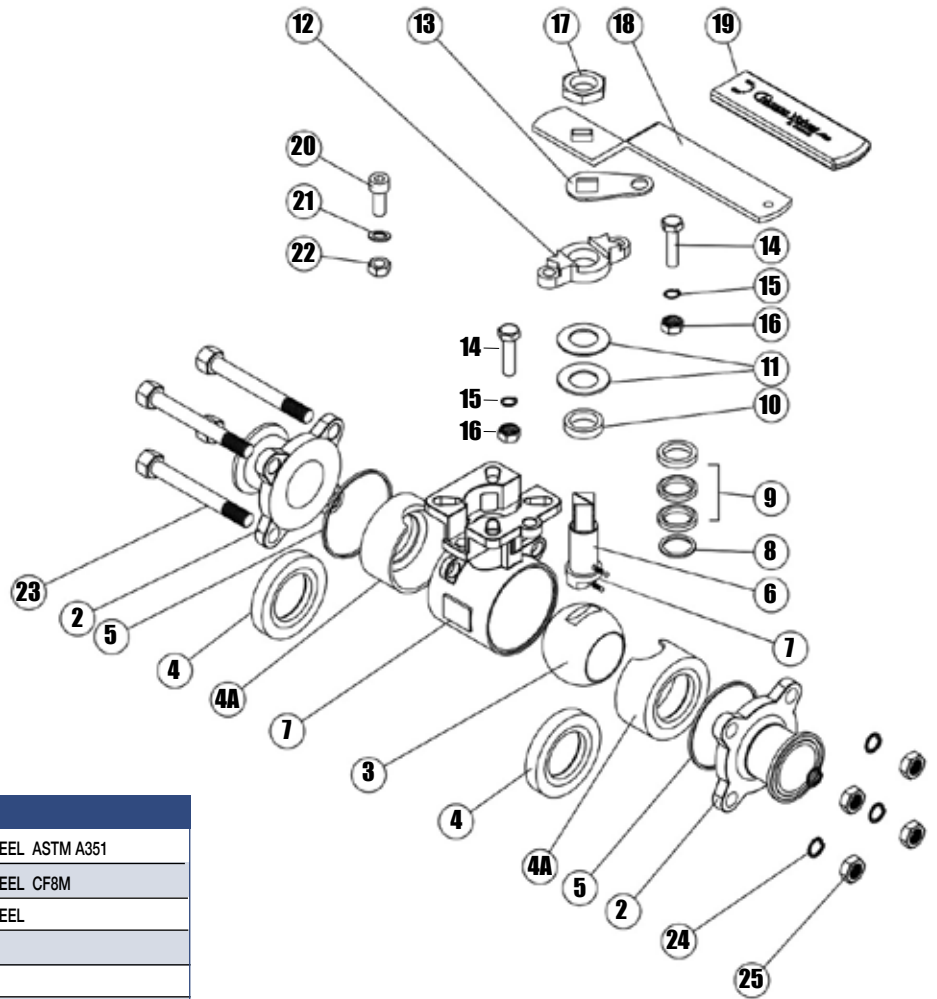

PART NO	PART NAME	QTY	MATERIAL
1	BODY	1	316 STAINLESS STEEL ASTM A351
2	END CAP	2	316 STAINLESS STEEL CF8M
3	BALL	1	316 STAINLESS STEEL
4	SEAT	2	TFM®/ PTFE
4A			
5	BODY SEAL	2	PTFE
6	STEM	1	304 STAINLESS STEEL
7	ANTI-STATIC DEVICE	2	316 STAINLESS STEEL
8	THRUST WASHER	1	PTFE
9	STEM PACKING	3	TFM 1600
10	GLAND PACKING	1	304 STAINLESS STEEL
11	BELLEVILLE WASHER	2	304 STAINLESS STEEL
12	GLAND FLANGE	1	304 STAINLESS STEEL
13	TRAVEL STOP/LOCKING DEVICE	1	304 STAINLESS STEEL
14	GLAND FLANGE BOLT	2	304 STAINLESS STEEL
15	SPRING WASHER	2	304 STAINLESS STEEL
16	GLAND BOLT NUT	2	304 STAINLESS STEEL
17	HANDLE NUT	1	304 STAINLESS STEEL
18	HANDLE	1	304 STAINLESS STEEL
19	HANDLE SLEEVE	1	PVC
20	BOLT STOPPER	1	304 STAINLESS STEEL
21	WASHER	1	304 STAINLESS STEEL
22	BOLT STOPPER NUT	1	304 STAINLESS STEEL
23	BODY BOLTS	4 6	304 STAINLESS STEEL
24	SPRING WASHER	4 6	304 STAINLESS STEEL
25	BODY BOLT NUT	4 6	304 STAINLESS STEEL

Series 36

1/2" - 4"

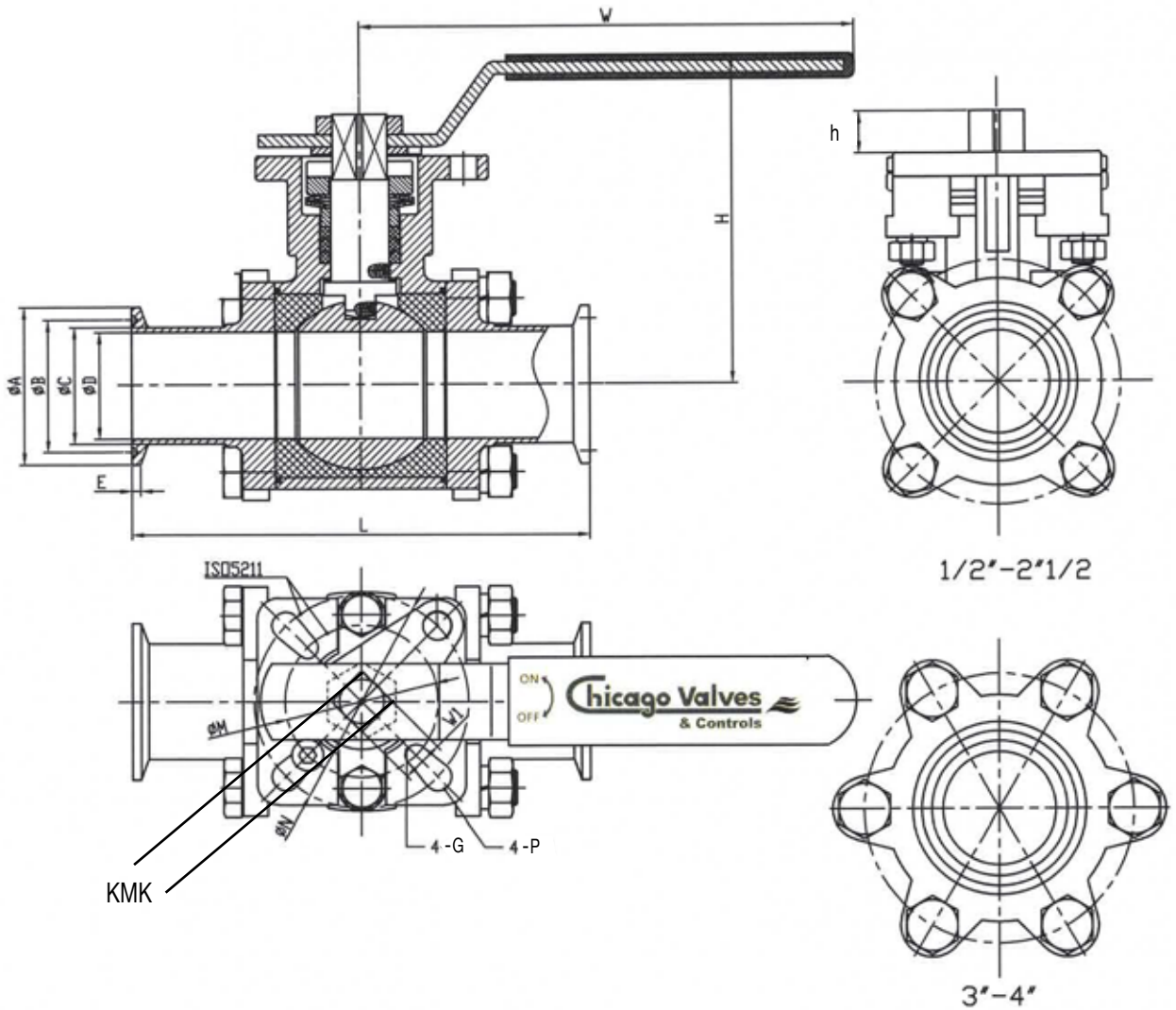

DIMENSIONS (INCHES)

NOMINAL DIAMETER	L	A	B	C	D	E	H	W	ISO 5211	N	M	G	P	h	KXX
1/2"	4.30	0.98	0.80	0.50	0.37	0.14	3.03	5.55	F03-F05	1.42	1.97	0.24	0.28	0.37	0.35
3/4"	4.70	0.98	0.80	0.75	0.62	0.14	3.15	5.55	F03-F05	1.42	1.97	0.24	0.28	0.37	0.35
1"	4.90	1.98	1.72	1.00	0.87	0.11	3.68	6.38	F04-F05	1.65	1.97	0.24	0.28	0.45	0.43
1 1/2"	5.60	1.98	1.72	1.50	1.37	0.11	4.53	7.40	F05-F07	1.97	2.76	0.28	0.35	0.63	0.55
2"	6.40	2.52	2.22	2.00	1.87	0.11	4.88	7.40	F05-F07	1.97	2.76	0.28	0.35	0.35	0.55
2 1/2"	7.80	3.05	2.78	2.50	2.37	0.11	6.24	9.17	F07-F10	2.76	4.02	0.35	0.43	0.75	0.67
3"	9.00	3.58	3.28	3.00	2.87	0.11	6.59	9.17	F07-F10	2.76	4.02	0.35	0.43	0.75	0.67
4"	9.60	4.68	4.34	4.00	3.83	0.11	7.42	13.00	F10-F12	4.02	4.92	0.43	0.51	0.94	0.87

Series 36

1/2" - 4"

SRE	CV (GPM)	WEIGHT(LBS)
1/2"	15	1.75
3/4"	30	1.90
1"	60	2.70
1 1/2"	130	5.60
2"	360	8.50
2 1/2"	780	19.75
3"	1130	30.50
4"	2100	49.00

APPLICABLE STANDARDS

BASIC DESIGN	ASME B16.34
CLAMP DESIGN	ASME BPE
BUTT WELD	ASME BPE
PRESSURE TEST	API 598
MOUNTING PADS	ISO 5211

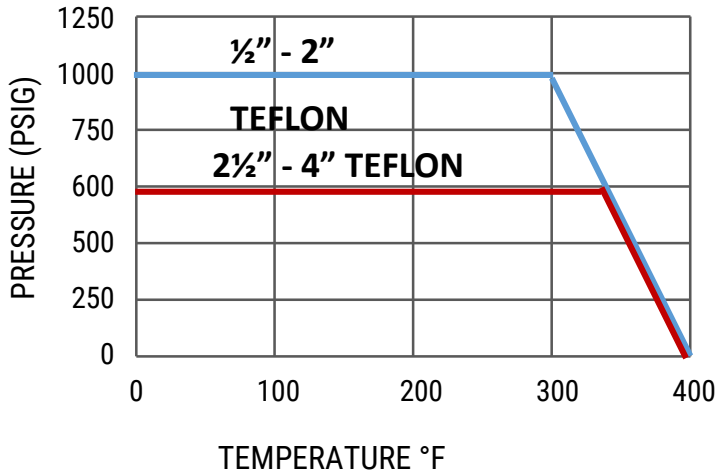
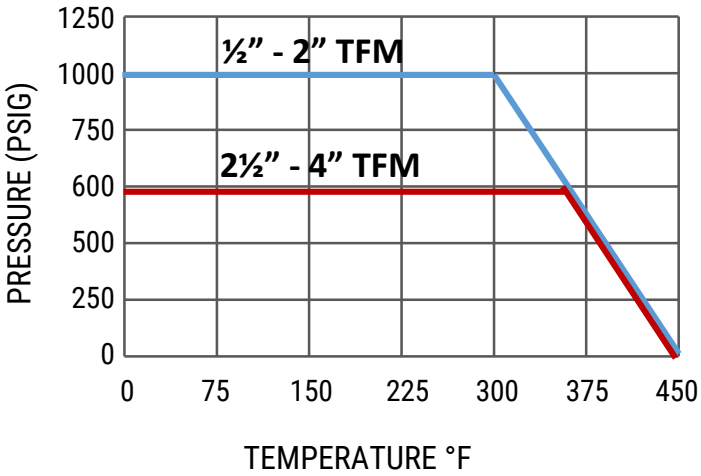

* PRESSURES MAY BE LIMITED BY THE TYPES OF CLAMPS AND FITTINGS USED WITH SERIES 36 VALVES

HOW TO ORDER

SIZE	SERIES	BODY & ENDS	BALL & STEM
1/2"	36	6 316 Stainless Stee	6 316 Stainless Steel
3/4"			
1"			
1 1/2"			
2"			
2 1/2"			
3"			
4"			

SEATS	
M	TFM*
T	PTFE (CAVITY FILL)

STEM PACKING	
M	TFM

ENDS	
CE	TRI CLAMPS
BE	BUTT WELD 316 SHORT TUBE
BTE	BUTT WELD TUBE EXTENDED 316L

OPTIONS	
X	OXYGEN CLEAN
OH	OVAL HANDLE
SF	SILICONE CLEAN
LEX	3.25" LOCKABLE EXTENDED STEM

Chicago Valves
& Controls



Toll-Free (833) 831-2312

Local (312) 636-3557

Fax: (312) 637-3543

Email: sales@chicagovalves.com

www.chicagovalve.com

835 Cambridge Dr.

Elk Grove Village, Illinois 60007 U.S.A.