

Installation, Operation, and Maintenance Manual

Series 82 Flanged Ball Valves

Sizes 1/2" – 4" , Classes 150, & 300

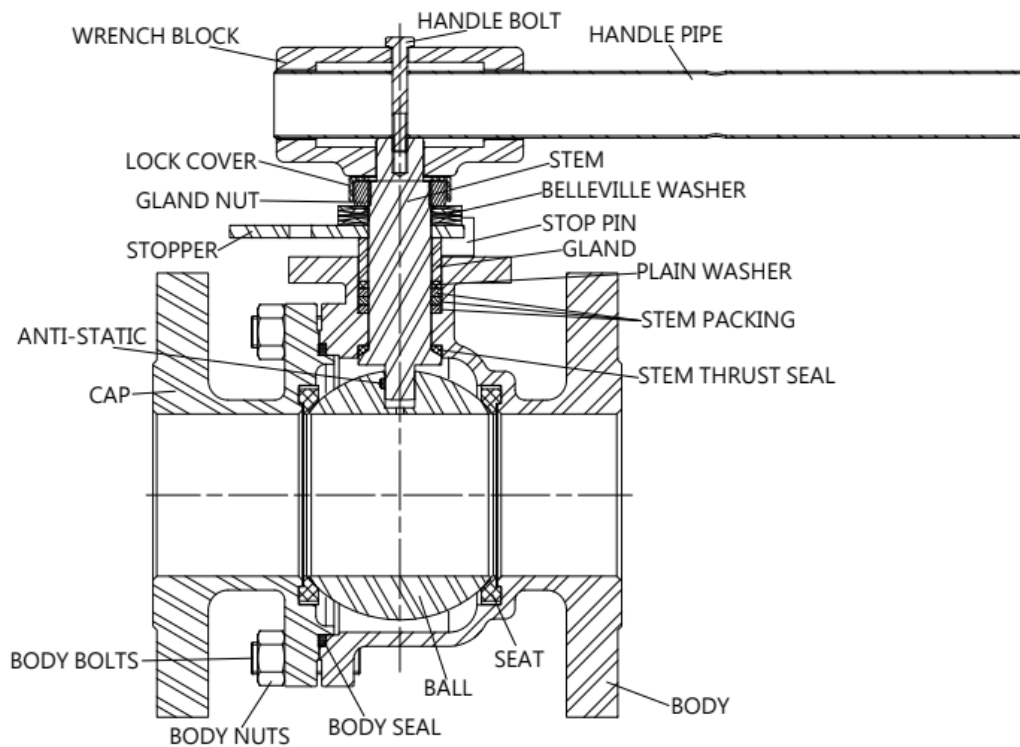

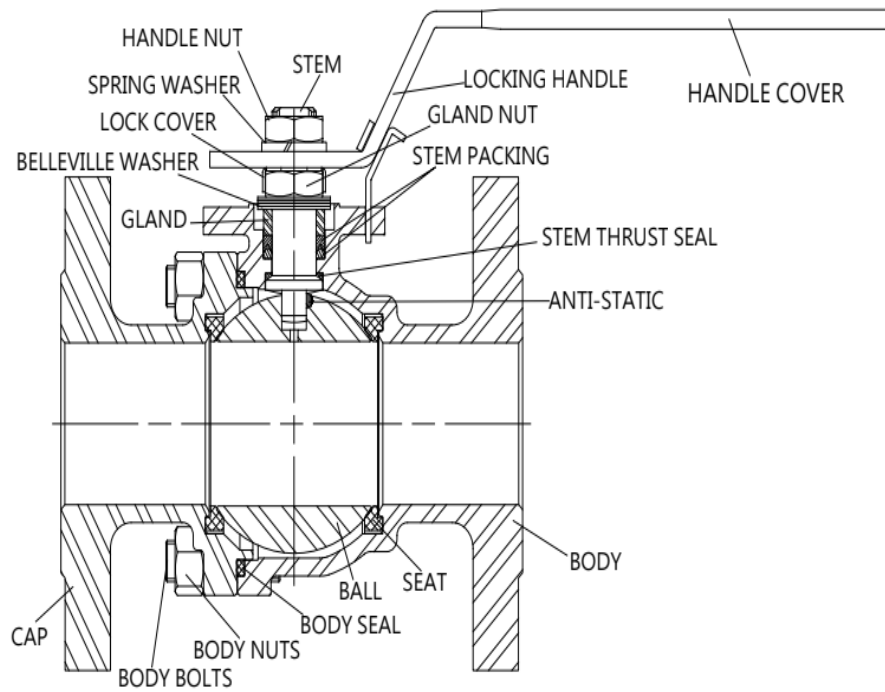

DESCRIPTION:

Split body, two piece construction full port ball valve. Design allows maintenance without the need for special tools.

INSTALLATION:

1. Before installing the valves, the pipes must be flushed clean of dirt, burrs and welding residues, or you will damage the seats and ball surface.
2. These valves may be installed in any position using good pipe fitting practices. Flanges conform to ASME Standard B16.5, Class 150, & 300.
3. Periodically check and tighten body joint and flange bolting. (See TABLE 1 for torque requirements.)

MANUAL OPERATION:

The valve is opened and closed by turning the handle $\frac{1}{4}$ turn (90°). Turning the handle clockwise closes the valve (handle perpendicular to pipeline). Turning the handle counterclockwise opens the valve (handle parallel to pipeline).

AUTOMATED OPERATION:

Valves with Actuators should be checked for alignment of the actuator to the valve. Angular or parallel misalignment may result in high operational torque, and potential damage to the stem seals or stem.

STEM SEAL ADJUSTMENT

Stem seal leakage may be corrected without disassembly. If leakage is evident in stem of packing area tighten the adjusting gland packing nut $\frac{1}{4}$ turn. If leakage persists, repeat above. Replacement of stem seals is indicated if the leak is still apparent after $\frac{1}{2}$ turn.

DISASSEMBLY:

-CAUTION-

If the Valve has been used to control hazardous media, it must be decontaminated before disassembly.

---WARNING---

Do not attempt to repair or partially disassemble a valve while it is in line and under pressure. Isolate the line, de-pressurize, and remove valve prior to performing maintenance.

1. Remove flange bolts and nuts and lift valve from line. Care should be taken to avoid scratching or damaging flange facings.
2. Remove handle and travel stop plate.
3. Remove stem nut locking tab, stem nut, Belleville springs, and gland ring from stem.
4. Remove body end nuts, using proper wrench size. Lift off body end. One seat should come out with body end.
5. Remove body seal.
6. To take out the ball, rotate stem so ball is in fully closed position. Carefully lift ball off stem tang and from body with a “rolling” motion. Use a strap and lift device, if necessary. Note: Extreme caution should be taken to avoid damage to the ball.
7. Take out other seat.
8. Stem must be removed from inside the body. The thrust bearing should come out with the stem. Then remove the stem packing.

VISUAL INSPECTION:

1. Clean and inspect all metal parts. Replace the ball and/or stem if the seating or sealing surfaces have been damaged, worn, or corroded.
2. Stem seals, seats, and body seal must be replaced whenever the valve is disassembled to avoid seal leakage and ensure proper performance.

ASSEMBLY:

Note: The valve may be assembled and operated dry where no lubricants are allowed in the system; however, a light lubrication of mating parts will aid in assembly and reduce initial operating torque. Lubricant used must be compatible with the intended line fluid.

1. Install one seat in the body cavity with the spherical curvature facing the ball.
2. Install thrust bearing on stem and slide the stem up through the body.
3. Install new Gland flange bolts and nuts. Install stem nut and tighten to the torque values given in Table 1. Install stem nut locking tab or cap. Tighten stem nut slightly if necessary to align nut with locking device surfaces.
4. Install travel stop (if supplied) and handle. Make sure handle aligns with flow bore through ball. Install hand retainer nut (or cap screw)
5. Turn the handle to the CLOSED position. Line up the ball slot with the stem tang and the ball into position on the stem tang. Turn the handle to the OPEN position to hold the ball in place.
6. Install the remaining seat into body end.
7. Place new body seal into counterbore in valve body.
8. Put body end into body and align the flange bolt holes to straddle the valve centerlines.
Note: Be careful not to damage body seal when putting end into body.
9. Install body end nuts and tighten in a "Star" pattern to the torque specified in Table 2. Take care to make sure that complete engagement of studs with body flange is maintained. There should be at least one stud thread exposed on each side.
10. Cycle the valve open and closed several times slowly to ensure that operation is smooth and free of binding or sticking.
11. Pressure test valve, if possible, before reinstalling in pipeline.

Table 1 - Stem Nut Torques

Valve Size	Torque (lb-ft)
1/2"	5.5
3/4"	5.5
1"	6
1-1/2" – 4"	22

Table 2 – Body Bolting Torques (lb-ft)

Valve Size	Class 150	Class 300	Class 600
1/2"	5	10	15
3/4"	5	10	20
1"	5	20	35
1-1/2"	15	35	80
2"	20	40	140
3"	20	60	155
4"	25	95	215

Note: Torque values are for TFE/RTFE or flexible graphite gaskets and seals. For other materials contact Chicago Valves.