

## Installation, Operation, and Maintenance Manual

### Fire Safe Series 81 Flanged Ball Valves

Sizes 1" – 4", Classes 150 and 300

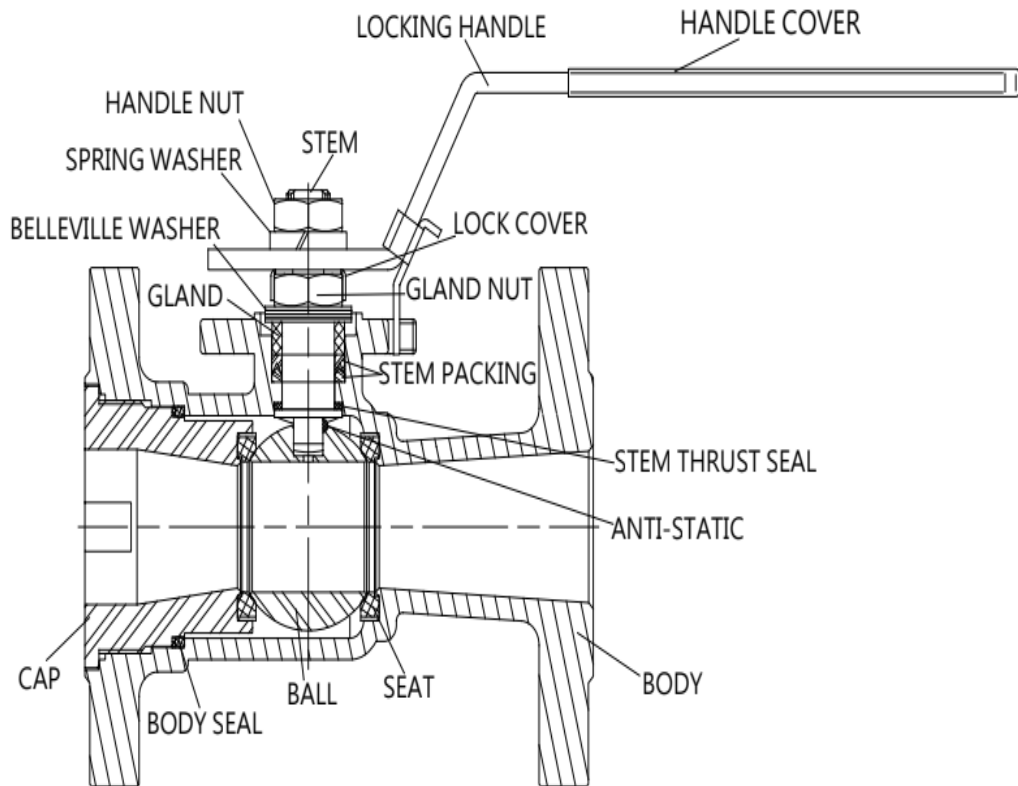

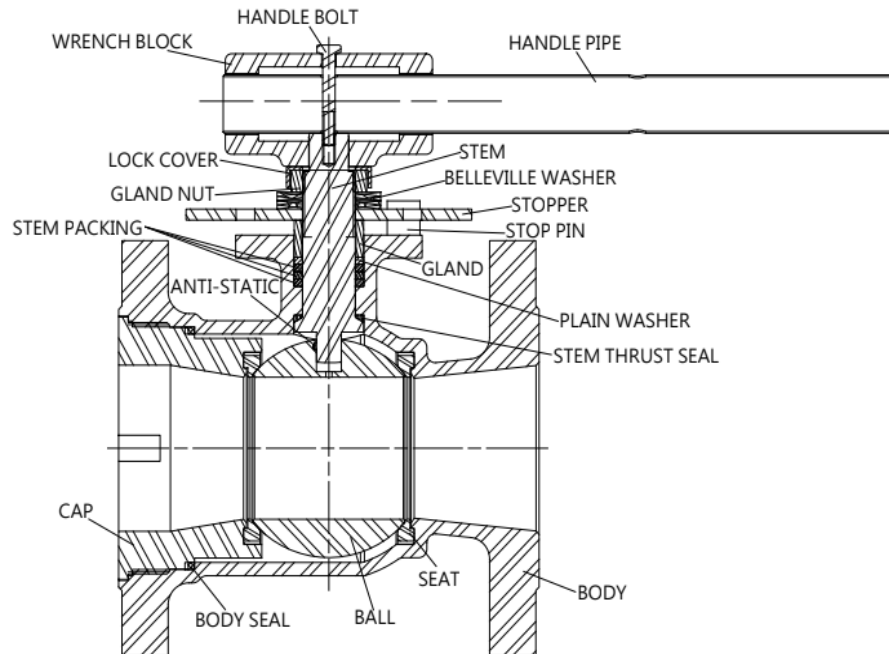

### **SAFETY INSTRUCTIONS:**

1. Read this Installation, Operation and Maintenance Manual before using the valve.
2. Chicago Valves cannot anticipate all the situations a user may encounter while installing and using the Chicago Valve. The user must know and follow all applicable industry specifications on the safe installation and use of these valves. Only qualified personnel or technicians who are trained for maintenance work and have read the instructions are to assemble and disassemble the valve. Misapplication of the product may result in injuries or property damage.

### **INSTALLATION:**

1. Before installing the valves, the pipes must be flushed clean of dirt, burrs and welding residues, or you will damage the seats and ball surface.\
2. These valves may be installed in any position using good pipe fitting practices. Flanges conform to ASME Standard B16.5, Class 150 and 300.

### **MANUAL OPERATION:**

1. The valve is opened and closed by turning the handle  $\frac{1}{4}$  turn ( $90^\circ$ ). Turning the handle clockwise closes the valve (handle perpendicular to pipeline). Turning the handle counterclockwise opens the valve (handle parallel to pipeline).

## **AUTOMATED OPERATION:**

Valves with Actuators should be checked for alignment of the actuator to the valve. Angular or parallel misalignment may result in high operational torque, and potential damage to the stem seals or stem.

## **STEM SEAL ADJUSTMENT:**

Stem seal leakage may be corrected without disassembly. If leakage is evident in stem packing area, tighten the adjusting nut 1/4 turn. If leakage persists, repeat above. Replacement of stem seals is indicated if the leak is still apparent after 1/2 turn.

## **DISASSEMBLY:**

### **-CAUTION-**

If the Valve has been used to control hazardous media, it must be decontaminated before disassembly.

### **---WARNING---**

Do not attempt to repair or partially disassemble a valve while it is in line and under pressure. Isolate the line, de-pressurized, and remove valve prior to performing maintenance.

1. Remove flange bolts and nuts and lift valve from line. Care should be taken to avoid scratching or damaging flange facings.
2. Remove handle and travel stop plate.
3. Remove stem nut locking tab, stem nut, belleville springs, and gland ring from stem.
4. Unscrew end cap, using spanner wrench. One seat should come out with end cap.
5. Remove body seal.
6. To take out the ball, rotate stem so ball is in fully closed position. Carefully lift ball off stem tang and from body with a "rolling" motion. Note: Extreme caution should be taken to avoid damage to the ball.
7. Take out other seat.
8. Stem must be removed from inside the body. The thrust bearing should come out with the stem. Then remove the stem packing.

## VISUAL INSPECTION:

1. Clean and inspect all metal parts. Replace the ball and/or stem if the seating or sealing surfaces have been damaged, worn, or corroded.
2. Stem seals, seats, and body seal must be replaced whenever the valve is disassembled to avoid seal leakage and ensure proper performance. Use only Chicago Valves replacement parts.

## ASSEMBLY:

**Note:** The valve may be assembled and operated dry where no lubricants are allowed in the system; however, a light lubrication of mating parts will aid in assembly and reduce initial operating torque. Lubricant used must be compatible with the intended line fluid.

1. Install one seat in the body cavity with the spherical curvature facing the ball.
2. Install thrust bearing on stem and slide the stem up through the body.
3. Install new stem seals, gland ring, and belleville springs. Install gland nut and tighten to the torque values given in Table 1. Install gland nut locking tab or cap. Tighten gland nut slightly if necessary to align nut with locking device surfaces.

Table 1 - Gland Nut Torques

Valve Size	Torque (lb-ft)
1"	6
1 ½" - 4"	22
6 - 8"	42

Note: Torque values are for TFE/RTFE or flexible graphite gaskets and seals. For other materials contact Chicago Valves.

4. Install travel stop (if supplied) and handle. Make sure handle aligns with flow bore through ball. Install hand retainer nut (or cap screw).
5. Turn the handle to the CLOSED position. Line up the ball slot with the stem tang and the ball into position on the stem tang. Turn the handle to the OPEN position to hold the ball in place.
6. Install the remaining seat into end plug.

7. Place new body seal into counter bore in valve body.
8. Install the end plug into body using the spanner wrench.  
**Note:** Be careful not to damage body seal when installing the end plug.
9. Cycle the valve open and close several times slowly to ensure that the operation is smooth and free of binding or sticking.
10. Pressure test valve, if possible, before reinstalling in pipeline.

### **TESTING:**

#### **---WARNING---**

Valve must be properly secured during testing. Fixture flanges for testing should be the same rating as the valves.

1. Secure valve to a test fixture by means of a mating flange with full bolting and a suitable gasket. Orient the valve so the seat to be tested is facing up.
2. Apply 50 to 100 psig air into the end of the closed valve which is attached to the fixture. Pour water into the upper port to cover the ball and visually check for bubbles. If bubbles are coming out, cycle the valve several times and recheck. To check for leakage in the other port, reverse the valve and repeat the process.
3. In the event of stem seal leakage, adjust as described under paragraph, "Stem Seal Adjustment".