

## Installation, Operation, and Maintenance Instructions Cast & Stainless-Steel Swing Check Valves CVC Series 41 & 416

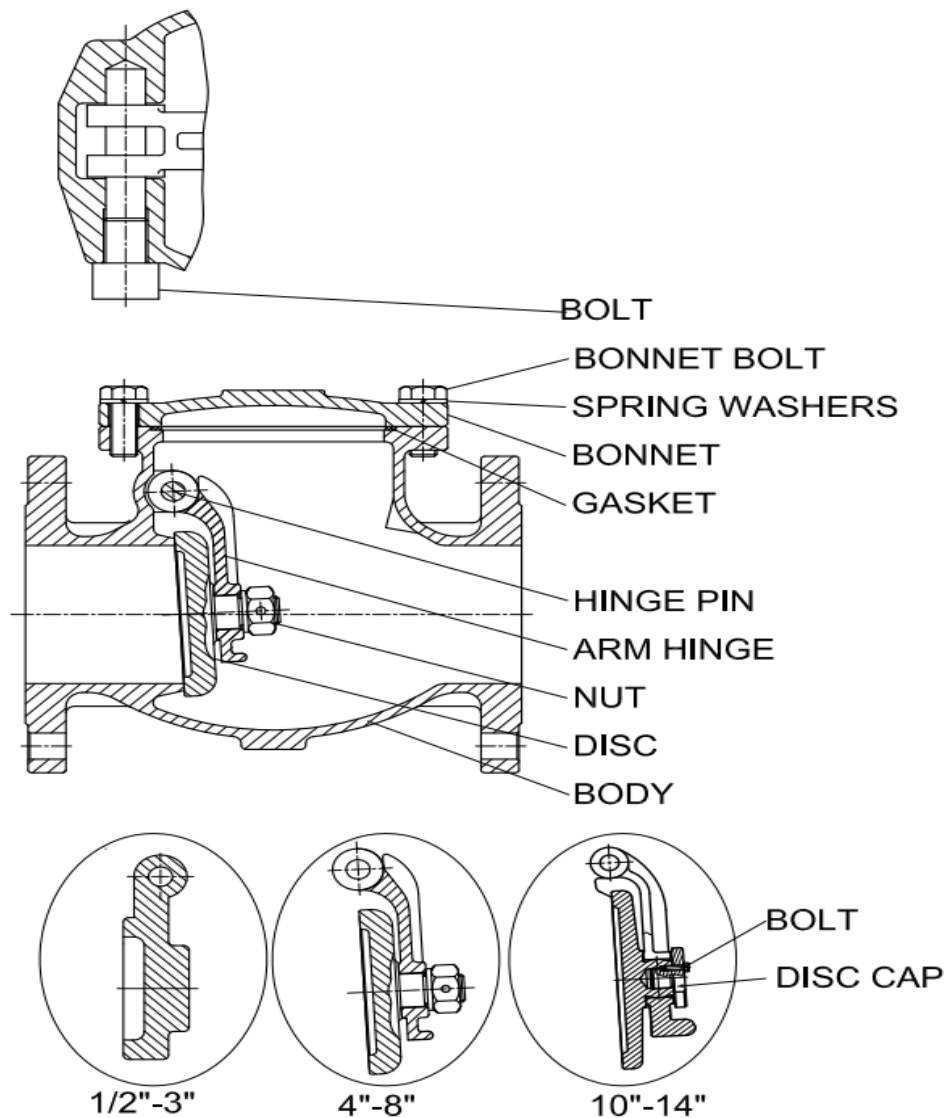

## **1. Applications:**

- 1.1 Valves are to be installed in a pipeline to prevent fluid flow from reversing direction.
- 1.2 Carbon steel and alloy steel valves are suitable for water, steam, oil, or other non-corrosive service.
- 1.3 Stainless steel valves are suited to corrosive service.

## **2. Operation:**

The Check valve disc is automatically opened or closed by fluid flow; allowing flow in the preferred direction and preventing flow in the reverse direction.

## **3. Storage, Protection, and Installation:**

- 3.1 Valves shall be stored in a dry warehouse, with end covers installed.
- 3.2 For in long term storage, valves shall be checked periodically, and cleaned to remove dirt and foreign material. Special care shall be taken for the cleanliness of seat surfaces, to prevent damage to the seat and disc.
- 3.3 Before installing the valve, check the valve identification tag carefully to verify that it is the correct valve for the application.
- 3.4 Before installing the valve, check inside passage and seal surface. Clean as necessary to remove all dirt and foreign material.
- 3.5 When installing the valve, make sure that the flow arrow on the valve is points in the required direction of flow.

## **4. Maintenance – Disassembly**

- 4.1 Confirm there is no pressure in the line before performing any maintenance on the valve.
- 4.2 Remove the bonnet bolt and nut to separate the bonnet from body.
- 4.3 Remove the gasket from the bonnet.
- 4.4 Loosen and remove plug and hinge pin, then carefully remove the disc assembly.
- 4.5 Disassemble the disc component to separate the hinge from disc.

## **5. Inspection and Maintenance:**

- 5.1 Refer to the troubleshooting chart on the following page for guidance in correcting problems.
- 5.2 Examine disc and seat surfaces for damage. Excessive wear or wire-drawing may require replacement of the damaged component. Minor damage or wear may be repaired by relapping or stoning the seat faces.
- 5.3 All gaskets and seals should be replaced after removal.

## **6. Reassembly:**

Reassemble the valve in the reverse order of disassembly. See Charts below for bolting torques.

## Troubleshooting Chart

Problem	Cause	Solution
Leakage between the body and bonnet	1. Bonnet bolts not tightened evenly	1. Re-tighten bolts evenly
	2. flange seal surface is damaged	2. repair flange seal surface
	3. gasket is damaged or incorrect.	3. replace with new gasket
Leakage of hinge pin, plug	1. plug isn't tightened	1. tighten the plug
	2. gasket is damaged or incorrect	2. replace with new gasket
Disc doesn't open or close	1. the connection of the hinge is damaged or jammed	1. check the connection
	2. foreign object stuck in valve	2. remove object
Valve is noisy and shaking/chattering	1. installation location is too near pump discharge	1. reinstall in a more suitable location
	2. the pipeline pressure is not steady	2. correct system pressure fluctuations

## Bonnet Bolt Torqueing Chart

Bolt Material: A193 B7

Diameter of bolt(in)	Torque(lb-in)	Diameter of bolt(in)	Torque(lb-ft)
1/4	40	1	267
5/6	81	1-1/8	380
3/8	147	1-1/4	530
7/16	244	1-3/8	730
1/2	353	1-1/2	940
9/16	527	1-5/8	1200
5/8	730	1-3/4	1520
3/4	1345	1-7/8	1860
7/8	2150	2	2330

Bolt Material: A320 B8

Diameter of bolt(in)	Torque(lb-in)	Diameter of bolt(in)	Torque(lb-ft)
1/4	16	1	108
5/6	32	1-1/8	153
3/8	58	1-1/4	216
7/16	96	1-3/8	294
1/2	140	1-1/2	378
9/16	210	1-5/8	475
5/8	290	1-3/4	617
3/4	540	1-7/8	745
7/8	860	2	935