

Series 33 3-Piece Full Port Ball Valve Installation, Operation, and Maintenance Instructions

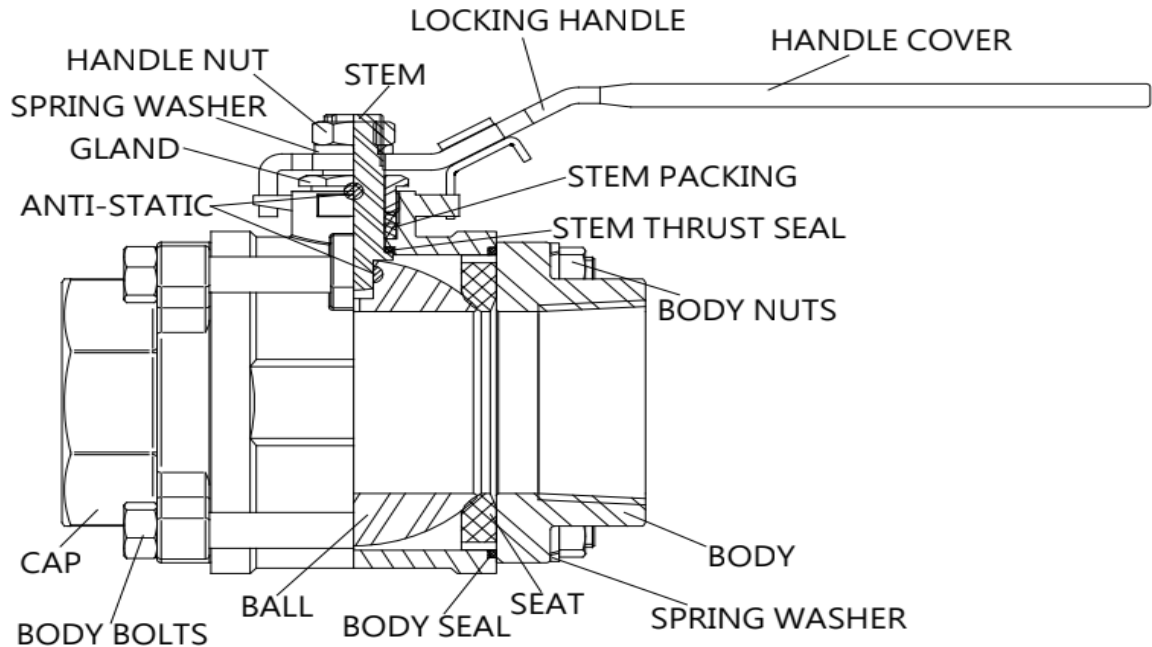

INSTALLATION:

These valves may be installed in the pipeline in any orientation or position, using good piping practice. For threaded end valves, use a suitable joint compound or TFE tape on pipe threads for ease of fit-up.

Welding End Valves:

Socket weld and butt weld end valves must be partially disassembled to prevent heat damage during welding of the soft plastic seats and seals in the valve. Prior to disassembly, the valve may be temporarily fitted in line, and the ends tack-welded to the piping for alignment purposes.

With the valve in the open position, remove the body hex nuts and lock washers, and the body hex bolts. Carefully lift out the center section, making sure that the seats are held in position. Place the center section in a clean area where it will not be damaged and complete the welding of the end caps to the piping.

When the welds are cool to the touch, install new seals supplied with valve and reinstall the center section between the body end caps. Re-install the body bolting and tighten following the "Assembly" instructions on the following page

OPERATION:

These are quarter-turn (90° rotation) ball valves and are fitted with a locking device handle for manual operation. The handles also contain travel stop tabs at the open and closed positions. To open the valve, lift the latch/lock slider up, and turn the handle clockwise. To close the valve, lift the locking device and turn the handle counterclockwise.

MAINTENANCE:

----WARNING----
**Do not attempt to perform
maintenance on valves in
pressurized lines.**

Stem Seal Adjustment:

If leakage is evident from the stem packing area, tighten the packing gland (below the handle) 1/8 turn. If the leakage persists, repeat tightening. If leakage cannot be corrected by tightening the gland, replacement of the stem packing will be necessary.

Seat & Seal Replacement:

Turn valve to the open position and remove handle nut, lock washer, and handle. Loosen and remove packing gland from valve body.

Loosen and remove body bolts, and remove body center section assembly, placing it on a suitable work surface. Remove seat and seals from body.

Using the handle if necessary, turn ball to the closed position, and remove ball from body with a rolling motion away from the stem. Handle ball with care to avoid damaging the surface.

Push downwards on the top of the stem to slide it through the stem seals, and remove stem from inside body bore. Remove thrust washer from stem, or from body bore if retained in body. Remove stem seals using a packing hook or sharp object.

C.V.C recommends that all soft parts, including seats be replaced with new parts, which can be ordered in kit form.

REASSEMBLY:

Make sure all valve components are clean and undamaged before assembly. Install thrust washer on stem, and slide down to shoulder. Insert stem into body and upwards through the stem bore until the shoulder is seated in the bore.

1. Slide stem seal over stem top, and into stem bore in body. Take care not to damage seal on stem threads. Install packing gland and tighten finger tight.
2. Place stem in the “closed” position and install the ball carefully by rolling the stem tang into the ball slot.
3. Install seat & seals in the body at each end, making sure the concave face fits against the ball, and press the body seal edge into the groove in the body face.
4. Turn ball to the “open” position and replace between the end caps in line. Slide body hex bolts through end caps and body guide holes, and secure with lock washers and hex nuts. Tighten snugly.
5. Tighten packing gland to the torque value table located on page 4, and replace the handle, lock washer, and handle nut.
6. Tighten the body bolting to the torque value table located on page 4, using a cross or star pattern to tighten evenly.

Torque Tables

Gland Packing (IN-LB)	
1/4"	35
3/8"	35
1/2"	80
3/4"	80
1"	115
1 1/4"	115
1 1/2"	115
2"	115

Body Bolts (IN-LB)	
1/4"	135
3/8"	135
1/2"	165
3/4"	175
1"	210
1 1/4"	240
1 1/2"	360
2"	360